

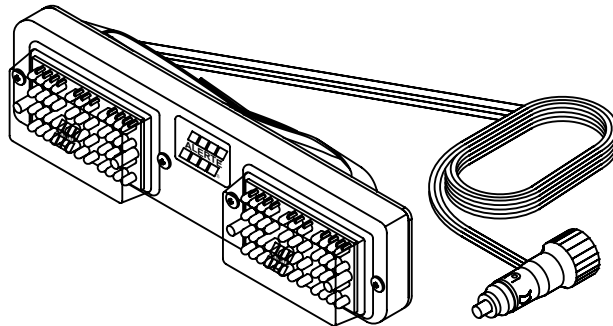

MODEL NO. 10.728
Visor Light 88
w/Quad Flasher



GENERAL INFORMATION:

Two super bright LED arrays, 44 LEDs per side. There are other array combinations to suit your jurisdiction or ordinance requirements from RED, BLUE, AMBER, GREEN, or WHITE LEDs. Each array equipped with vertical rows of white LEDs at their outer edges to provide the "halo" effect pioneered by ALERTE to enhance visibility.

- Quad Alternating Flash Pattern

INSTALLATION INSTRUCTIONS:

Position the "Visor Light" on the visor, normally on the passenger side with the lenses facing downward when the visor is in the up position.

Fasten the straps over the visor and position the "Visor Light" with its bottom edge even with the lower edge of the visor. Tighten the straps to snug the "Visor Light" against the visor.

Clean the cable clip location on the windshield column and the dash with 409®, Fantastic®, or the equivalent prior to affixing the clips. This procedure is particularly important if a silicone-based protectant such as Armor All® has been used on these surfaces. Failure to adequately clean the clip mounting locations may prevent the adhesive on the clips from securing a sound, long-lasting grip.

Place the cable in the clips. Open the clips only as much as necessary to insert the cable.

To operate, flip the visor down, insert the cable plug into the cigarette lighter socket and switch on.

NOTE: If the "Visor Light" is to be permanently wired, please specify at the time of the order, so when manufacturing your light we can adjust the location of the switch. The current switch is located on the cigarette adapter.

ALERTE SYSTEMS INC

901 W 10th Street / P.O. Box 586 / Cassville, MO 65625

Local & International Numbers:
Phone 417-846-2222 / Fax 417-846-2506

U.S. and Canada Toll-Free Numbers:
Phone 800-728-1536 / Fax 800-635-1536

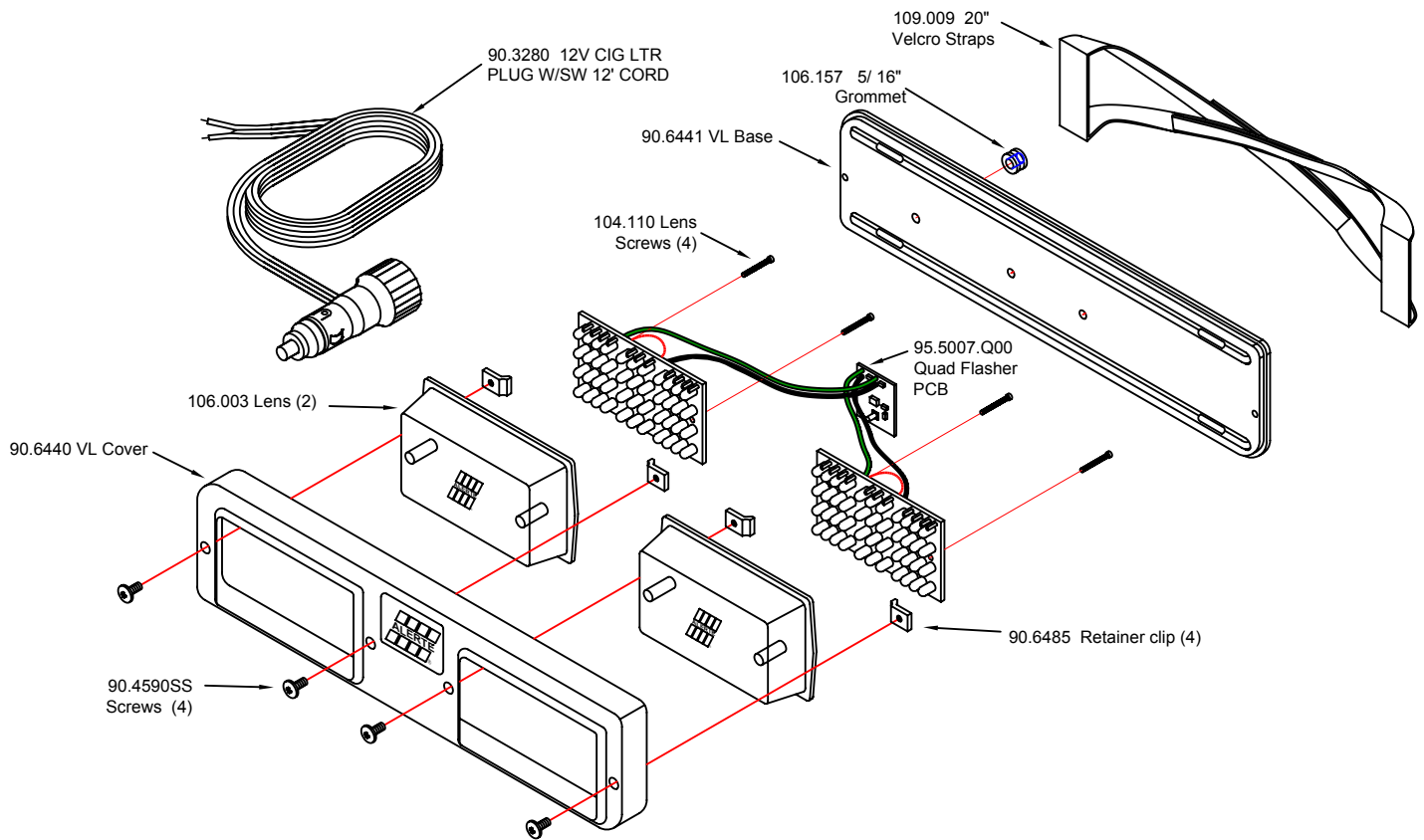

LIMITED WARRANTY

ALERTE warrants each new product (except bulbs, strobe power supplies and strobe tubes) to be free from defects in material and workmanship for a period of two years from the date of purchase. During this warranty period, the obligation of ALERTE is limited to repairing or replacing, as ALERTE may elect, any part or parts, which after examination by ALERTE are determined to be defective, when they are delivered pre-paid. This limited warranty does not cover travel expense, the cost of specialized equipment for gaining access to the product, or labor charges for the removal and re-installation of the product.

ALERTE shall not be liable for incidental or consequential damages, including but not limited to: loss of use of vehicle, rental of substitute vehicle, loss of time, loss of work, inconvenience, transportation expenses, telephone, lodging, loss of revenue, loss of and/ or damage to personal property for or arising out of breach of any express or implied warranty of its products.

Use of lamp or other electrical load of wattage higher than installed or recommended by the factory, or use of inappropriate or inadequate wiring or circuit protection causes this limited warranty to become void. ALERTE will in no way be liable for any loss of profits or any indirect or consequential damages arising out of any such defect in material and workmanship whether loss is due to negligence or breach of warranty. This limited warranty does not apply to shipping damage, accident, alteration, tampering, misuse or abuse and unauthorized service.

This limited warranty is expressly in lieu of all other express or implied warranties, including the implied warranty of merchant ability and the implied warranty of fitness for a particular purpose, and of all other obligation or liabilities on the part of ALERTE. There are no warranties, unless expressed in authorized ALERTE literature, which extend beyond the description of the face hereof. No dealer, distributor, employee, or representative of the company is authorized to change this warranty in any way or to grant any other warranty.

PRODUCT RETURNS

If a product must be returned, contact our factory by calling 1-800-728-1536 to obtain a Return Authorization Number (RA) before you ship the product. Write the RA number clearly on the package and return it to ALERTE Systems International, Ltd., 901 West 10th Street, P.O. Box 586, Cassville, MO 65625. A packing slip should be included with all shipments listing the sender's name, address, daytime phone number and description of defect. Your product will be put in first-class operating condition or replaced with a new part, and returned pre-paid.