

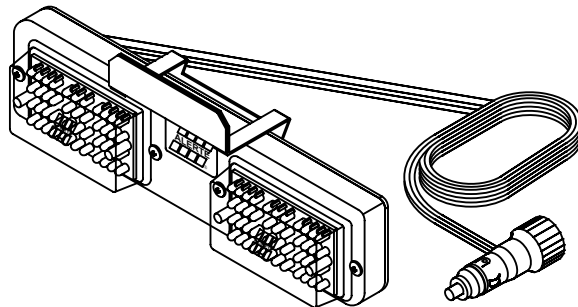

MODEL NO. 10.744
Mark 12
w/Quad Flasher



GENERAL INFORMATION:

Two super bright LED arrays, 44 LEDs per side. There are other array combinations to suit your jurisdiction or ordinance requirements from RED, BLUE, AMBER, GREEN, or WHITE LEDs. Each array equipped with vertical rows of white LEDs at their outer edges to provide the "halo" effect pioneered by ALERTE to enhance visibility.

- Quad Alternating Flash Pattern

INSTALLATION INSTRUCTIONS:

The "Mark 12" is a self contained, quad flash light system equipped with LED arrays that can be mounted in any of several locations within a vehicle.

After choosing a location for the "Mark 12", bend the mounting bracket, if necessary, to insure that the unit will hang vertically. Carefully clean the selected glass location with an alcohol swab.

CAUTION: The adhesive backed tape used to secure the light is a very aggressive contact tape that is virtually impossible to remove or relocate.

Once you have carefully chosen a location, remove the film from the foam tape adhered to the mounting bracket. Place the bottom edge of the foam tape against the chosen spot, tilt the bracket upward to adhere the tape to the glass, and apply pressure to the back of the foam tape portion of the bracket to secure it and to remove any trapped air.

If you need a "Mark 12" for direct wire, please specify at the time of the order, so when manufacturing your light we can adjust the location of the switch. The current switch is located on the cigarette adapter.

ALERTE SYSTEMS INC

901 W 10th Street / P.O. Box 586 / Cassville, MO 65625

Local & International Numbers:
Phone 417-846-2222 / Fax 417-846-2506

U.S. and Canada Toll-Free Numbers:
Phone 800-728-1536 / Fax 800-635-1536

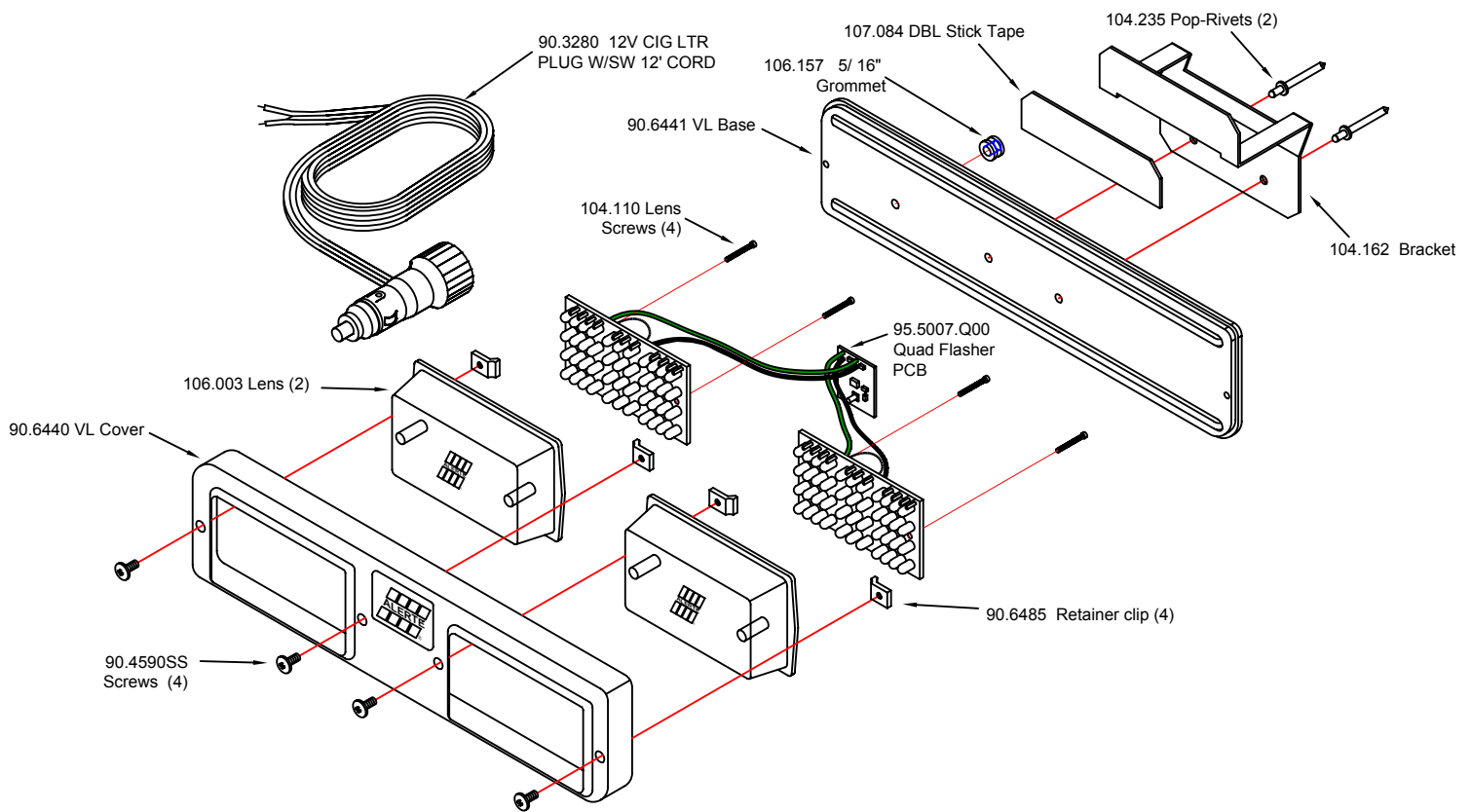

LIMITED WARRANTY

ALERTE warrants each new product (except bulbs, strobe power supplies and strobe tubes) to be free from defects in material and workmanship for a period of two years from the date of purchase. During this warranty period, the obligation of ALERTE is limited to repairing or replacing, as ALERTE may elect, any part or parts, which after examination by ALERTE are determined to be defective, when they are delivered pre-paid. This limited warranty does not cover travel expense, the cost of specialized equipment for gaining access to the product, or labor charges for the removal and re-installation of the product.

ALERTE shall not be liable for incidental or consequential damages, including but not limited to: loss of use of vehicle, rental of substitute vehicle, loss of time, loss of work, inconvenience, transportation expenses, telephone, lodging, loss of revenue, loss of and/ or damage to personal property for or arising out of breach of any express or implied warranty of its products.

Use of lamp or other electrical load of wattage higher than installed or recommended by the factory, or use of inappropriate or inadequate wiring or circuit protection causes this limited warranty to become void. ALERTE will in no way be liable for any loss of profits or any indirect or consequential damages arising out of any such defect in material and workmanship whether loss is due to negligence or breach of warranty. This limited warranty does not apply to shipping damage, accident, alteration, tampering, misuse or abuse and unauthorized service.

This limited warranty is expressly in lieu of all other express or implied warranties, including the implied warranty of merchant ability and the implied warranty of fitness for a particular purpose, and of all other obligation or liabilities on the part of ALERTE. There are no warranties, unless expressed in authorized ALERTE literature, which extend beyond the description of the face hereof. No dealer, distributor, employee, or representative of the company is authorized to change this warranty in any way or to grant any other warranty.

PRODUCT RETURNS

If a product must be returned, contact our factory by calling 1-800-728-1536 to obtain a Return Authorization Number (RA) before you ship the product. Write the RA number clearly on the package and return it to ALERTE Systems International, Ltd., 901 West 10th Street, P.O. Box 586, Cassville, MO 65625. A packing slip should be included with all shipments listing the sender's name, address, daytime phone number and description of defect. Your product will be put in first-class operating condition or replaced with a new part, and returned pre-paid.